



**PERFORMANCE DATA SHEET
NEMA PREMIUM NR CAN NEMA 12 - 12**

Catalogue #: JMPPS-2

HP	kW	Voltage	S.F. @ 60Hz	EFF.	P.F.	Frame	Design	L.R. Amps
1	0,75	575	1,15	85,5%	0,644	143JM	B	12

60 Hz								
FLA							Code	F.L. RPM
208	230	416	460	480	575	600		
/	/	/	/	/	1,36	/	K	1740

50 Hz								
FLA			S.F. @ 50Hz	Efficiency	Power Factor	Code	F.L. RPM	
190	380	415						
/	/	/	/	/	/	/	/	

Wgt. Lbs	PH	Duty	Insul. Class	Amb.	Elevation	Temp. Rise° C
36	3	Cont.	F	40°C	1000M (3300 Ft)	25

% Efficiency		% Power Factor		Torque		Winding Resist. Ω	Safe Cold Start (Secs)
Full Load:	85,5%	Full Load:	0,64	Full Load Ft/Lbs	3,0		
3/4 Load:	84,2%	3/4 Load:	0,60	Locked Rotor %	300		
1/2 Load:	78,0%	1/2 Load:	0,47	Break Down %	310	19	12

Rotor Inertia Wk2 Lb-Ft2	Max Load Inertia Wk2 Lb-Ft2	Shaft Material	Frame Material	DE Bracket Type	ODE Bracket Type	Enclosure	NEMA Rating	Lead Wire Size
0,04	8,5	Stainless Steel				TEFC	IP69K	16AWG

Ball Bearings		Grease	Mount Type	Orientation	Paint	Sound Pressure @ 3FT	Sound Power
DE	ODE						
6205	6205	Sealed Bearings	Rigid	Horizontal	-	61	70

Inverter Duty. Motor meets MG1 parts 31.4.4.2	Constant Torque Range	Variable Torque Range	Constant HP RPM
	10:1	20:1	2700

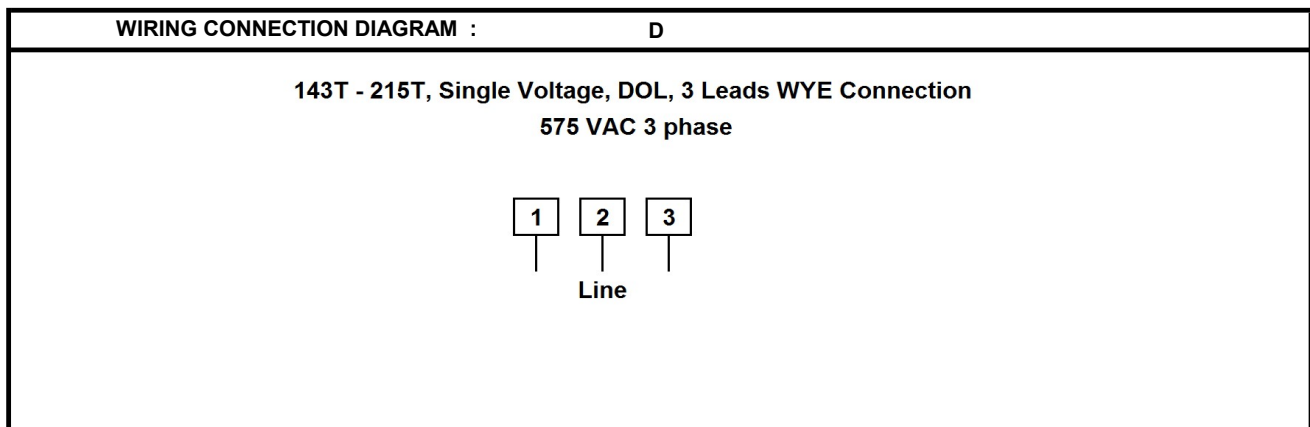

Date: 2022-08-30
 Customer: _____
 Contact: _____
 Submittee: J.C. Lavallée

Catalogue #: **JMPPS-2**

NEMA PREMIUM NR CAN NEMA 12 - 12										
HP	VAC	RPM	Enclosure	Frame	Frequency	Design	Poles	LR Code Letter	Insulation Class	Temp. Rise °C
1	575	1740	TEFC	143JM	60	B	4	K	F	25
	0Hz	6Hz	15Hz	30Hz	45Hz	60Hz	75Hz	90Hz	105Hz	120Hz
Amps	1,36	1,36	1,36	1,36	1,36	1,36	1,36	1,36	1,36	1,36
RPM	0	174	435	870	1305	1740	2175	2610	3045	3480
Torq ft.lb	2,41	2,41	3,02	3,02	3,02	3,02	2,41	2,01	1,72	1,51
Peak Tq ft.lb	3,85	7,70	7,70	7,70	7,70	7,70	6,16	5,13	4,40	3,85
HP	0	0,1	0,3	0,5	0,8	1,0	1,0	1,0	1,0	1,0
	Locked Rotor	Pull-Up	Breakdown	Rated Load	Idle	Duty	S. F.	Ambient	Elevation	dBa @ 1M
Speed (RPM)	0,0	756	1440	1740	1800	Continuous	1,15	40°C	3,300 ft	61
Current (Amps)	12,0	10,2	7,1	1,4	0,6	VFD Rating: Meets MG1 parts 31.4.4.2				
Torque (ft-lbs)	9,1	7,7	9,4	3,0	0,0	C.T.	10:1	V.T.	20:1	

Motor Speed Data

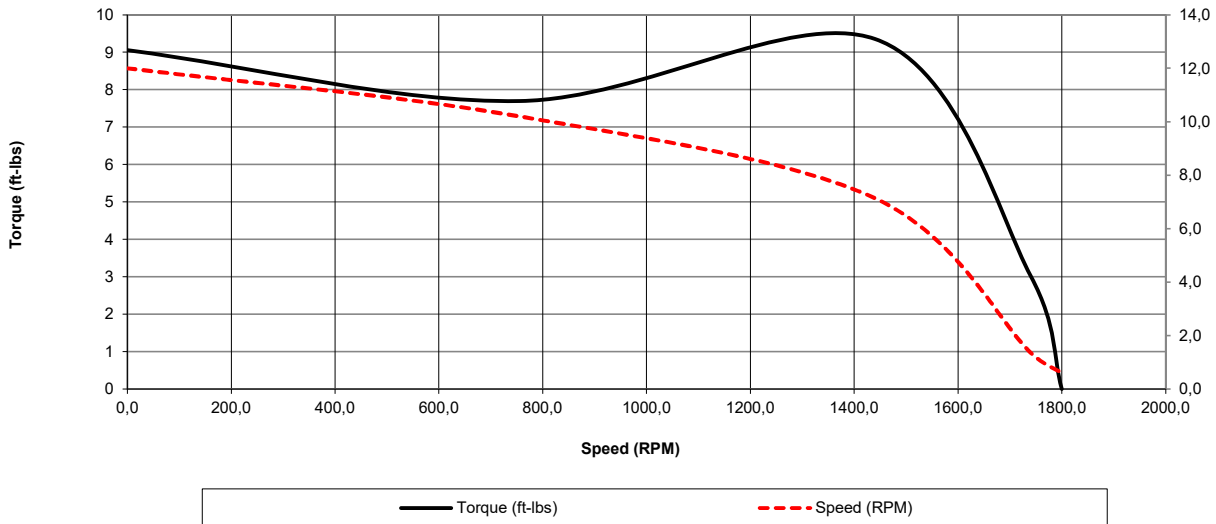

Motor Torque Capability vs RPM

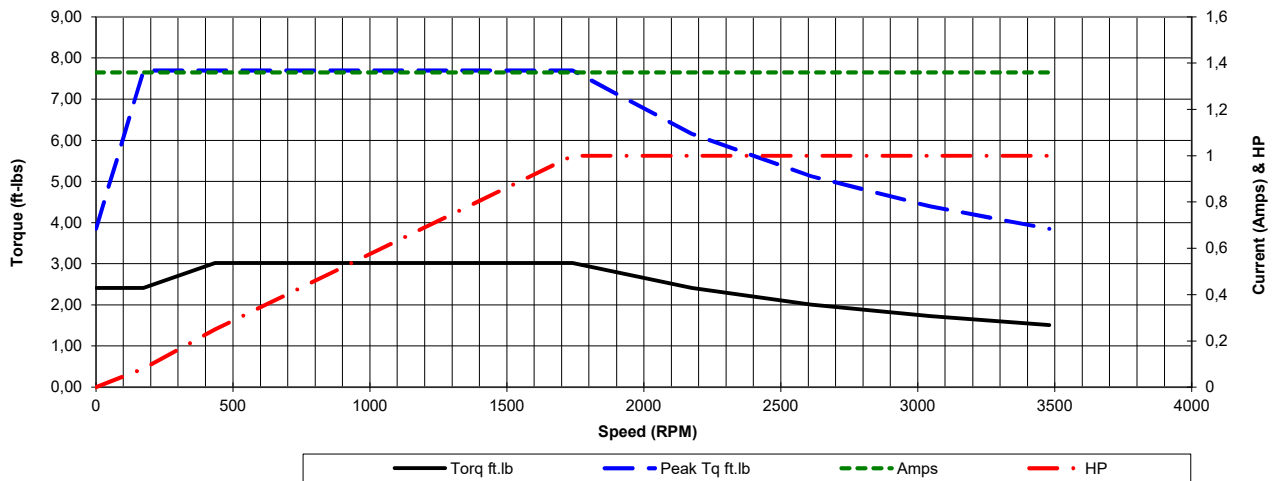

Date: 2022-08-30
 Customer: _____
 Contact: _____
 Submittee: J.C. Lavallée

Catalogue #: **JMPPS-2**

NEMA PREMIUM NR CAN NEMA 12 - 12

HP	VAC	RPM	Enclosure	Frame	Frequency	Design	Poles	LR Code Letter	Insulation Class	Temp. Rise °C
1	575	1740	TEFC	143JM	60	B	4	K	F	25

Load %	0%	25%	50%	75%	100%	125%	150%
Amps	0,61	0,64	0,83	1,07	1,36	1,67	1,99
Torq ft/lbs	0	0,74	1,48	2,24	3,02	3,81	4,61
RPM	0	1785	1770	1755	1740	1725	1710
Eff	0	65,52	78,00	84,20	85,50	85,50	85,50
PF	0	35,0	47	60	64,4	65,7	66,0

	Locked Rotor	Pull-Up	Breakdown	Rated Load	Idle	Duty	S. F.	Ambient	Elevation	dBA @ 1M
Speed (RPM)	0	756	1440	1740	1800	Continuous	1,15	40°C	3,300 ft	61
Current (Amps)	12	10,2	7,1	1,36	0,612	VFD Rating: Meets MG1 parts 31.4.4.2				
Torque (ft-lbs)	9,06	7,70	9,36	3,02	0,0	C.T.	10:1	V.T.	20:1	

Motor Speed Data

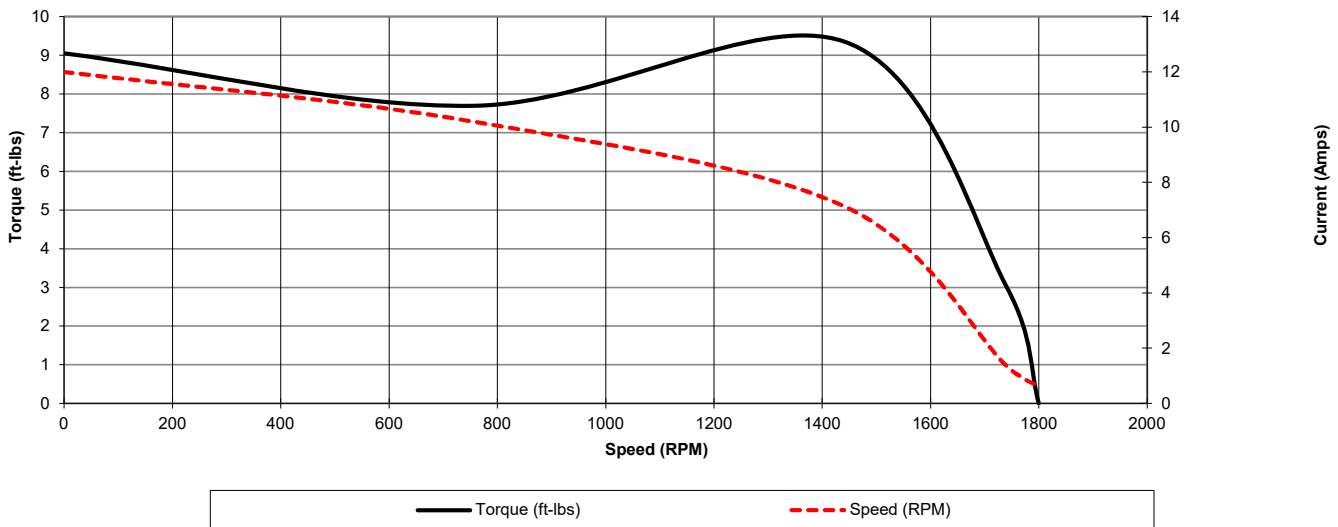

Motor Load Data

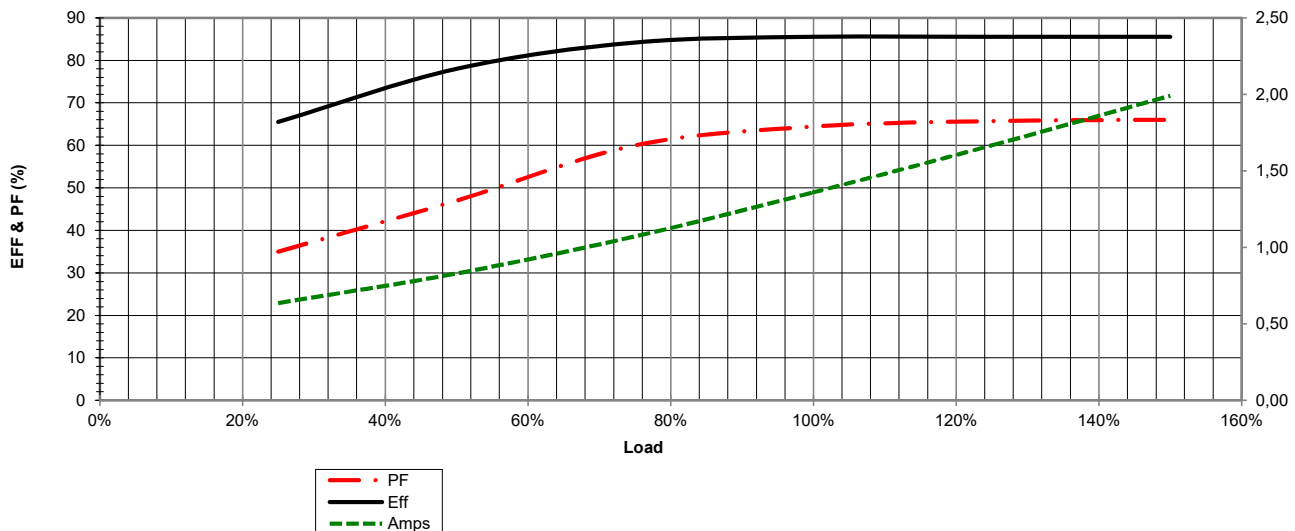

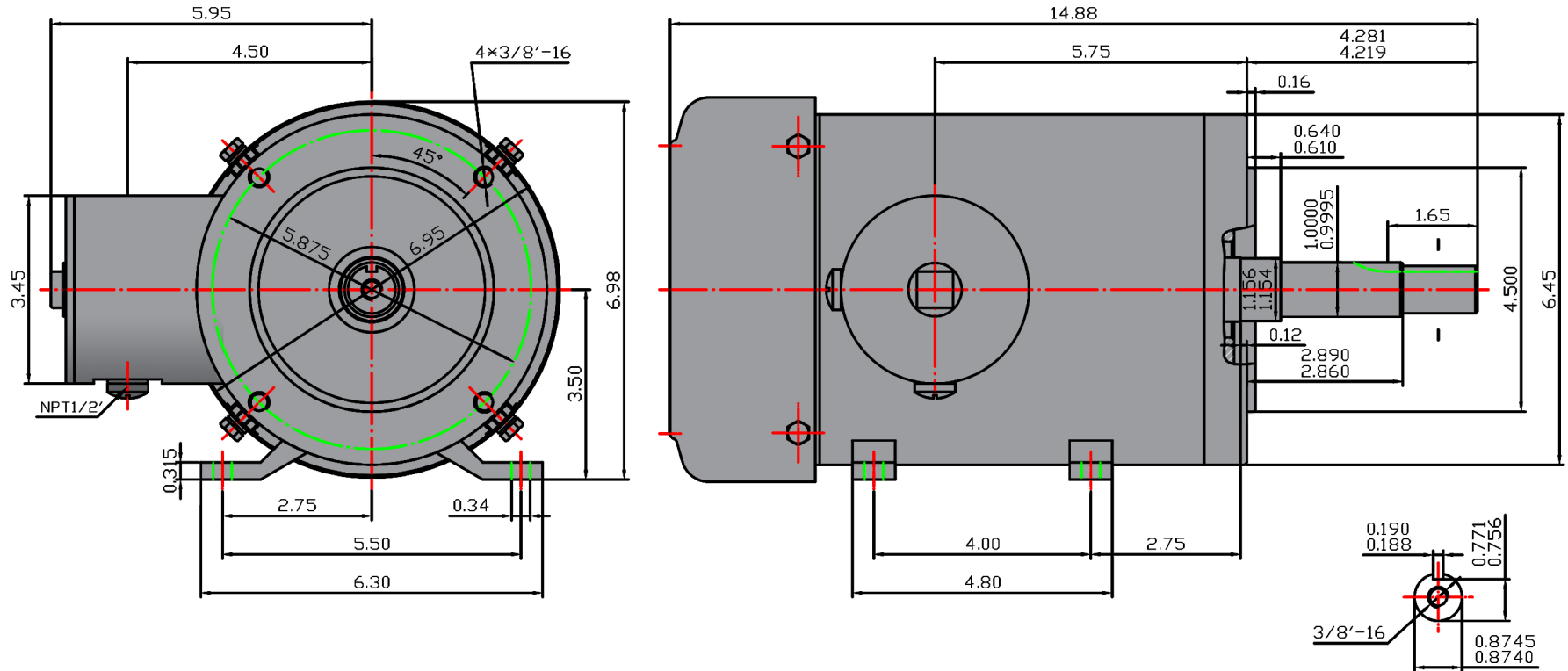

Version:1WEI	Revised: August 2022	HP	RPM	FRAME	ENCLOSURE	JMQPS/JMPPS-2
Customer is responsible in determining that MaxMotion product will fit/perform suitably in the intended application		1	1800	143JM	TEFC	

PREMIUM DESIGN B NEMA 12-12

CLOSE COUPLED PUMP MOTORS JM STYLE | STAINLESS STEEL
CONSTRUCTION L BASE TEFC TOTALLY ENCLOSED FAN COOLED

MaxMotion

Applications:

A durable and versatile close coupled pumps motor design that can be base or flange mounted to equipment operating in wet and severe conditions, and where wash down duty and corrosive elements are found.

Features:



Design - NEMA standard MG-1, Design B meets MG-1 Part 31

Agency listings and standard - Meets or exceeds MEPS (Minimum Efficiency Performance Standards) as described by US Department of Energy in docket 10CFR431 and Natural Resources Canada's Amendment 14. Also CSAus and CE Certified.

Service Factor - 1.15

Electrical Supply - At 60Hz: 575V and 208-230/460-480V dual rated and at 50Hz: 190/380.

Windings - Highest quality Enamel coated Corona resistant inverter duty magnet wire. VPI with additional dip and bake.

Insulation - Non hygroscopic class F with class B temperature rise

Voltage and frequency variation - +/- 10% as based on two voltage points of the motor being either 230 / 460 or 333 / 575

Bearing - Double sealed with Lithium grease -30 Deg to 180 Deg C

Enclosure Protection - Meets Ingress Protection Standard IP69K

Construction - Paint free with all 304 Stainless steel housing and shaft. Moisture proof sealant on all machined fits and shielded Viton type double lip seal . Four condensation plugs on each end shield for mounting flexibility.

Terminal Box - The round welded terminal box design comes completely encapsulated and offers two points of entry for easy access to the terminals. All while eliminating points where contaminants can build up, and maintaining the motors IP69K rating.

Inverter duty - Inverter Duty 10:1 Constant Torque, 20:1 Variable Torque

Nameplate - Permanently etched to stainless steel housing

Warranty - 18 Months



PREMIUM DESIGN B NEMA 12-12

CLOSE COUPLED PUMP MOTORS JM STYLE | STAINLESS STEEL
CONSTRUCTION L BASE TEFC TOTALLY ENCLOSED FAN COOLED



HP	FL RPM	VOLTS	FRAME	CAT NO.	CONSTRUCTION	NOM EFF.	F.L. AMPS	CODE	WT (Lbs)	DE BRG	ODE BRG	"C" Dimension (Inch)
1	1740	575	143JM	JMPPS-2	STAINLESS STEEL	85.5%	1.36	K	36	6205	6205	14.88
	1740	208-230/460	143JM	JMQPS-2	STAINLESS STEEL	85.5%	3.76-3.4/1.7	K	36	6205	6205	14.88
1 1/2	1740	575	145JM	JMPPS-7	STAINLESS STEEL	86.5%	1.76	K	42	6205	6205	16.06
	1740	208-230/460	145JM	JMQPS-7	STAINLESS STEEL	86.5%	4.87-4.4/2.2	K	42	6205	6205	16.06
2	3480	575	145JM	JMPPS-11	STAINLESS STEEL	85.5%	1.92	K	46	6205	6205	16.06
	3480	208-230/460	145JM	JMQPS-11	STAINLESS STEEL	85.5%	5.31-4.8/2.4	K	46	6205	6205	16.06
	1740	575	145JM	JMPPS-12	STAINLESS STEEL	86.5%	2.16	K	49	6205	6205	16.06
	1740	208-230/460	145JM	JMQPS-12	STAINLESS STEEL	86.5%	5.97-5.4/2.7	K	49	6205	6205	16.06
3	3535	575	182JM	JMPPS-16	STAINLESS STEEL	86.5%	3.24	K	81	6308	6306	18.58
	3535	208-230/460	182JM	JMQPS-16	STAINLESS STEEL	86.5%	8.96-8.1/4.05	K	81	6308	6306	18.58
	3535	575	145JM	JMPPS-16S	STAINLESS STEEL	86.5%	3.24	K	53	6205	6205	17.83
	3535	208-230/460	145JM	JMQPS-16S	STAINLESS STEEL	86.5%	8.96-8.1/4.05	K	53	6205	6205	17.83
	1765	575	182JM	JMPPS-17	STAINLESS STEEL	89.5%	3.2	K	89	6308	6306	18.58
	1765	208-230/460	182JM	JMQPS-17	STAINLESS STEEL	89.5%	8.85-8.00/4.00	K	89	6308	6306	18.58
5	3525	575	184JM	JMPPS-21	STAINLESS STEEL	88.5%	4.88	J	95	6308	6306	18.58
	3525	208-230/460	184JM	JMQPS-21	STAINLESS STEEL	88.5%	13.49-12.2/6.1	J	95	6308	6306	18.58
	1765	575	184JM	JMPPS-22	STAINLESS STEEL	89.5%	5	J	104	6308	6306	18.58
	1765	208-230/460	184JM	JMQPS-22	STAINLESS STEEL	89.5%	13.82-12.5/6.25	J	104	6308	6306	18.58
7.5	3520	575	213JM	JMPPS-26	STAINLESS STEEL	89.5%	7.52	H	110	6308	6208	21.82
	3520	208-230/460	213JM	JMQPS-26	STAINLESS STEEL	89.5%	20.79-18.8/9.4	H	110	6308	6208	21.82
	1755	575	213JM	JMPPS-27	STAINLESS STEEL	91.7%	7.44	H	163	6308	6208	21.82
	1755	208-230/460	213JM	JMQPS-27	STAINLESS STEEL	91.7%	20.57-18.6/9.3	H	163	6308	6208	21.82
10	3525	575	215JM	JMPPS-31	STAINLESS STEEL	90.2%	9.76	H	175	6308	6208	21.82
	3525	208-230/460	215JM	JMQPS-31	STAINLESS STEEL	90.2%	26.98-24.4/12.2	H	175	6308	6208	21.82
	1760	575	215JM	JMPPS-32	STAINLESS STEEL	91.7%	9.76	H	200	6308	6208	22.62
	1760	208-230/460	215JM	JMQPS-32	STAINLESS STEEL	91.7%	26.98-24.4/12.2	H	200	6308	6208	22.62



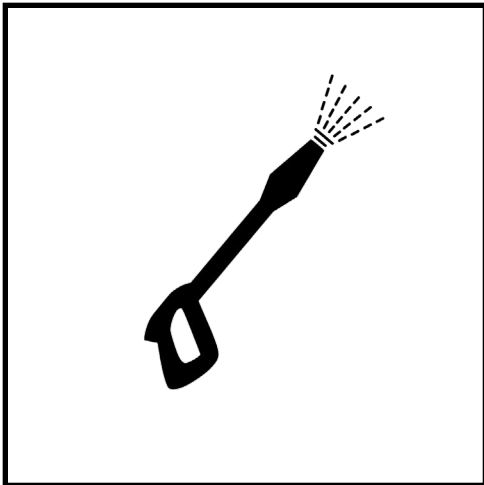

When this power wash icon is displayed, this means the fixture is rated IP69K.

What is IP69K?

The IP69K rating is for applications where high pressure and high temperature wash-down are used to sanitize equipment. The IP69K test specification was initially developed for road vehicles, especially those that need regular intensive cleaning (dump trucks, cement mixers, etc.), but has been widely adopted in the Food & Beverage industries as a test of products to withstand sanitary washdown.

More specifics on IP69K

In applications where devices were regularly exposed to high-pressure or high temperature wash downs, the highest ratings of IP68 was sometimes found to be insufficient. Therefore, a special rating was created by ISO to test this intensive cleaning. In the IEC 60529 rating system, IP6 refers to the product's ability to resist ingress of dust. The 69K refers to the product's ability to resist ingress of high temperature (steam) / high pressure water.

Only if the device passes this test can it be considered IP69K rated and used in harsh environments with high pressure / steam cleaning.

Testing procedure per ISO 20653:

(depicted in image to right)

- A spray nozzle that is fed with 80°C water at 80–100 bar (~1160-1450) and a flow rate of 14–16 L/min.
- The nozzle is held 10-15cm from the tested device at angles of 0°, 30°, 60° and 90° for 30 seconds each.
- The test device sits on a turntable that rotates once every 12 seconds.

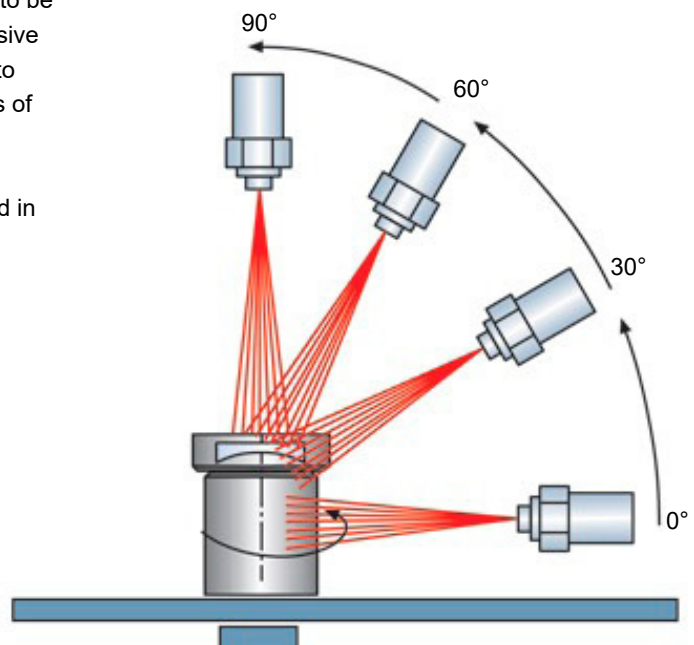

IP68, IP69 and IP69K - The facts

Even though you can do an internet search for IP69, it is important to note that there is no IP69 rating. The IP chart goes from IP68 to IP69K. In addition, just because IP69K is a higher number does not mean the coverage or rating is higher or better than IP68. In fact, IP68 and IP69K are very different ratings. While both share the same first digit "6" which is protection against the ingress of solid objects and are rated as dust tight, that is where the similarity ends. IP68 is rated for prolonged immersion in water, IP69K as noted above involves pressure washing at high temperatures.